

Model R® Drain Cleaning Machine

ITEM NUMBER	PART NUMBER	DESCRIPTION	AMT
1	R-10*****	Frame	1
2	R-12*****	Handle	1
3*	R-W10	10" Diameter x 5/8 Wheels	2
4	PN58	Push Nut	2
5	R-3	Axle	1
6	WA58P	Washers	4
7	CP532114	Cotter Pin	2
8	R-11	Motor Tension Spring	1
9	R-23****	Motor Mount Assembly	1
10	R-22****	Adapter Plate Assembly	1
11	CSHH516181	Motor Mount Capscrews	4
12	WA516S	Motor Mount Washers	4
13	LW516	Motor Mount Lockwashers	4
14	NU51618FHP	Motor Mount Nuts	4
15	R-18	Belt Guard	1
16	DL-4	Thumb Screw	2
17	R-HPC	Hairpin Clip	1
18	RM-1/3	Motor - 1/3 HP, 115 Volt, 60 cycles	1
19	N-8	Motor Pulley	1
20	A48	V-belt	1
21	SW-FR	Forward/Reverse Switch	1
22	SW-FRP	Forward/Reverse Switch Plate	1
23	TBS3218	Air Activated On/Off Switch	1
24	FP-1A**	Air Bulb Foot Pedal with Hose	1
25	FP-1	Foot Pedal	1
26	FP-2	Air Hose	1
27	GFC1	Ground Fault Circuit Interrupter 20' Cord	1
28	R-20***	Cable Cage with Anchor	1
29	R-14	Cable Anchor	1
30	WS 12	Wing Screw	1
31	OBSF324016	Rear Bronze Bushing	1
32	OBSS324216	Front Bronze Bushing	1
33	TSC 12	Two Screw Connector	1
34	SW-Boot	Forward/Reverse Switch Boot	1
35	SS51618516	Set Screw	1
36	DL6CAP	Cord Hook Cap	4
37	SS5162458DP	5/16 - 24 x 5/8 Set Screw Dog Point	1
38	NU51624FHP	5/16 - 24 Hex Nut	1

Model R® Drain Cleaning Machine

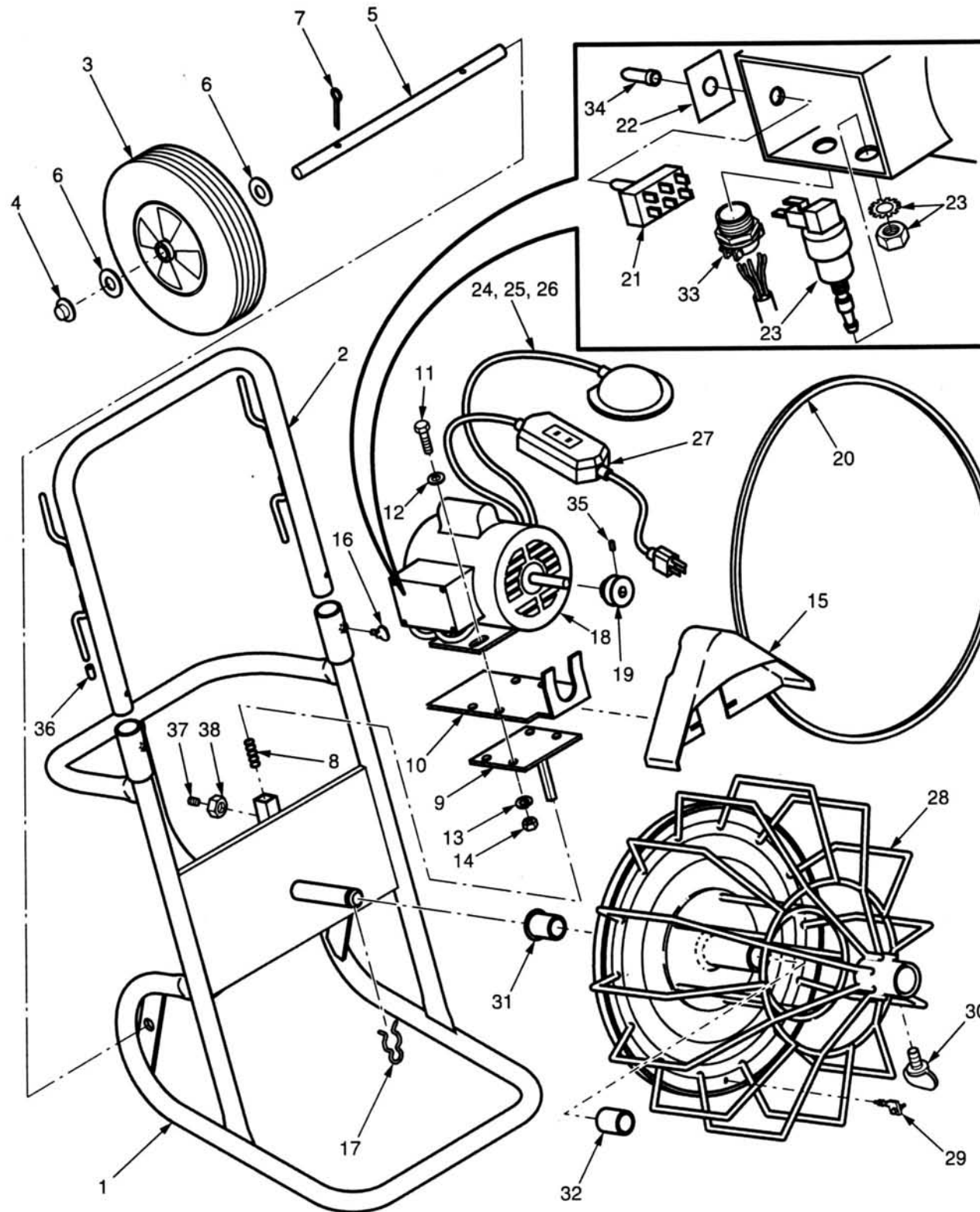

EE-R1\_rev3

- \* Includes Item 4
- \*\* Includes Items 25, 26
- \*\*\* Includes Items 17, 29, 30, 31, 32
- \*\*\*\* Prior to Serial No. 5047, Item #9 part no. is R-16 and Item #10 part no. is R-17
- \*\*\*\*\* Includes Items 8, 9, 10, 37, 38
- \*\*\*\*\* Includes Item 36

OVER >

Rev. 01/2012 I-9

*Electric Eel*®

**MODEL R®**  
**Sewer and**  
**Drain Cleaning Machine**

Operator's Manual



Purchase Date: \_\_\_\_\_  
Serial Number: \_\_\_\_\_

**!! DANGER !!**  
**FOR YOUR SAFETY**  
Before you operate or maintenance this equipment, READ this manual carefully and completely!



**ELECTRIC EEL MANUFACTURING CO., INC.**  
501 West Leffel Lane, Springfield, Ohio 45501-9985  
Call Toll-Free (800) 833-1212 (937) 323-4644 FAX: (937) 323-3767  
www.electriceel.com Proudly Made in The USA Since 1939



## Description/Specifications

### DESCRIPTION

The ELECTRIC EEL Model R® Drain Cleaning Machine is one of the finest, most dependable and rugged of ELECTRIC EEL's complete line of quality sewer and drain cleaning equipment. This machine is specifically designed for the professional when cleaning 3 to 6 inch diameter lines and using up to 100 feet of cable.

### SPECIFICATIONS

Line Capacity .....	3 to 6" dia. with up to 100 feet of cable
Weight (Machine only) ..	95 lbs.
(with cable) .....	195 lbs.
Frame .....	1" open space framework of welded tube
Tires .....	10" semi-pneumatic (10-14 psi)
Cage capacity .....	100 ft. 3/4" TRIMAX inner-core cable (Std)
Power .....	1/3 HP Capacitor Start motor (115 V AC standard)
Controls .....	Air foot switch and 20 ft. cord assembly with built in ground fault circuit interrupter
Note .....	All new units include 4 cleaning tools, one pair of reinforced leather gloves and one cable spanner wrench

#### Standard tools included with Model R



HDD-7 retriever tool



HDD-3S root saw



U3H grease tool



A-1DC starting drill

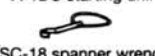

SC-18 spanner wrench

## Safety Instructions

The following safety rules for operating ELECTRIC EEL's Model R Drain Cleaning equipment **MUST** be read carefully before operating this machine.

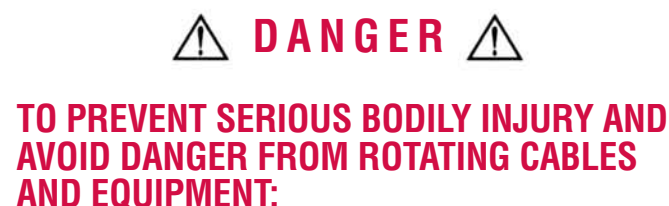

## General Safety

1. **ALWAYS** wear heavy reinforced leather gloves and safety glasses when operating this equipment.
2. Place this machine within 3 feet of inlet between sewer opening and machine. Keep both hands on rotating cable during operation, **UNLESS THE CABLE IS UNDER TENSION.**
3. **NEVER HANDLE ANY CABLE UNDER TENSION.\* ALWAYS** relieve all tension build-up before attempting to handle cable. Make sure that the machine and power are off.
4. Use foot switch to operate machine while keeping good footing and balance at all times. **DO NOT OVERREACH!**
5. **DO NOT WEAR** loose clothing or jewelry while operating this machine.

\*Relieve all tension build-up before attempting to handle cable.

## General Safety (cont.)

6. The Model "R" Drain Cleaning Machine should be **OPERATED BY ONE PERSON ONLY.** Additional personnel in the work area should observe all safety instructions.
7. Wear rubber-soled **NON-SLIP SHOES, HEAVY LEATHER** gloves, and **EYE** protection. **ALWAYS** keep belt guard in place during operation.
8. **ALWAYS AVOID** direct contact or splashing of drain water on skin, facial area and especially the **EYES.** Chemical compounds used in drains can result in serious burns and other injuries.
9. **REPLACE** fittings, cables, and any rotating parts as soon as they become visibly worn. **REPLACE** any cables which become fractured, rusted, bent, kinked, or otherwise damaged.
10. **NEVER** attempt to service equipment beyond the recommendations of the operating instructions. All other servicing should be referred to qualified Electric Eel service personnel.
11. To maintain safe operation, **USE ONLY** identical replacement parts and cables from Electric Eel.
12. **ALWAYS KEEP CLEAR** of rotating drums, cages, shafts, pulleys, belts, or other rotating parts.
13. **DO NOT** continue to operate machine when cleaning tool becomes stuck in obstruction. **EXCESS TORQUE ON A CABLE COULD CAUSE IT TO FRACTURE.**
13. Reverse rotation if necessary to prevent unnecessary build-up of torque on a cable. Keep machine under control at all times.
14. **NEVER** force a tool and cable into pipeline blockage. This may overload the cable or tool and cause fracture to either the tool or the cable.
15. Use **CORRECT TOOL** for the job or application. Check the tool chart and use the proper tool for the size of the line being cleaned.
16. To maintain safe and efficient operation **CLEAN THOROUGHLY** all cables and tools with water after use. Chemicals in the drain and sewer lines can attack and deteriorate the metal of the cables and tools. Deterioration can cause premature fracture or breakage in tools or cable.



## TO AVOID SERIOUS BODILY INJURY AND TO AVOID DANGER FROM ELECTRICAL SHOCK:

1. **ALWAYS** use a ground fault interrupted circuit with a properly grounded outlet for all electrical cords, connections, and parts as installed by factory. **DO NOT** make any alterations.
2. **NEVER** use machine in damp or wet conditions.
3. **NEVER** expose machine to rain.
4. **THE USER SHOULD NEVER ATTEMPT TO SERVICE THE ELECTRICAL COMPONENTS.** For safety reasons all electrical replacement components should be installed by a qualified electrician.
5. Before making adjustments or changes to power units, disconnect from electrical source.

## THE GROUND FAULT CIRCUIT INTERRUPTER

This machine is equipped with a **Ground Fault Circuit Interrupter** which is designed to prevent a serious electrical shock. This device should be tested on the job site **BEFORE** putting the machine into operation, as follows:

1. To ensure protection against electrical shock, test the device before each use. When test button is pushed in, the indicator light should go OFF. Reactivate the device by pushing the reset button in. If the indicator light goes ON, the device is ready for use. **DO NOT** use the device if the indicator light does not go ON WHEN RESET or if the indicator light REMAINS ON, when the TEST BUTTON IS PUSHED IN.
2. This device **DOES NOT** guard against electrical shock resulting from defects or faults in any wiring supplying power to this device, or from contact with both circuit conductors.
3. **DO NOT** use with an extension cord on the plug end unless the power source is equipped with a ground fault interrupter circuit and properly grounded.
4. **ONLY** use 14 ga. or larger, three-wire, extension cord (with ground wire), with three-prong grounding plugs and three-pole receptacles.
5. When using extension cord outdoors, **ONLY** use those intended for outdoor use. (Indicated on cord by suffix, "W-A", after cord type).

## Operating Instructions



## OPERATOR MUST BE THOROUGHLY FAMILIAR WITH ALL SAFETY INSTRUCTIONS BEFORE OPERATING THIS EQUIPMENT

### MANUAL CABLE FEED

1. Place the machine within 3 ft. of the drain or sewer clean out.
2. Attach a small spear-type cleaning tool to the end of the cable. This tool will enable you to bore a starter hole in the obstruction, allowing backed-up water to drain. **NOTE:** A 2 ft. flexible leader should be used when negotiating P-traps or severe bends in the line.
3. Position foot actuator for easy operator accessibility.
4. Make sure FOR/REV switch is in the Forward position.
5. With the machine in the off position, hand feed the cleaning tool and cable into the sewer line clean out as far as can be easily done.
6. With gloved hands on cable, begin depressing the foot actuator to start the machine. **ALWAYS** keep two hands on the cable in order to guide and control the rotating cable.
7. Apply downward pressure with gloved hands on cable; rotating cable will slowly work its way into the line.
8. Repeat steps 6 and 7 until the obstruction is met. This will become apparent as operator can no longer feed additional cable into the line and/or cable slows or fails to rotate. **WARNING: DO NOT ALLOW** machine to run when cleaning tool becomes stuck in the obstruction and cable fails to rotate. This will cause **EXCESS CABLE TENSION** and allow the cable to kink, and/or break due to excess torque build-up. If tool becomes stuck, switch motor from Forward to Reverse operation, and slowly back tool out of obstruction.
9. To work tool through obstruction, place toggle switch in Forward direction and begin running cable into line. When the cable hits an obstruction and starts to load, the operator should pull on cable in order to back tool away from obstruction. This procedure should continue until tool has fully worked its way through the obstruction.

**NOTE:** For larger lines, it will be necessary to repeat steps 5 through 9 with a larger tool or blade after the obstruction has been penetrated.

10. To retrieve cable from sewer line, manually pull cable from sewer and hand feed back into the machine with it running in forward rotation. **NOTE:** It is recommended that you use a continuous flush of water to clean tool, cable and sewer line as cable is retrieved.
11. As tool nears coming out of the drain or sewer opening, release foot actuator and allow machine to come to complete stop.
12. Pull remaining cable and tool from sewer line and hand-feed cable back onto machine.

## MAINTENANCE

Maintenance on the Model R® machine should be minimal for the life expectancy of the machine. The cable cage is equipped with bearings which do not need to be lubricated, but an occasional lubrication with oil to the machine shaft will help in removal of cable cage and will not harm the bearings. A light coating of oil applied to the cable before storing will help prevent rusting and premature failure.

## REMOVING CABLE CAGE

Whenever it is necessary to remove the cable cage from the machine, disconnect all power, manually remove the V-belt by turning the cable cage by hand and turning the belt off the large pulley. Then remove the retaining clip from the end of the shaft and slide cable cage off. Reverse the above procedure in replacing the cable cage. It is usually easier to replace the cable cage with the machine laid on its back so that the shaft is in a vertical position. **MAKE SURE TO REPLACE THE BELT GUARD.**

## REMOVING THE HANDLE

The handle can be removed from the machine for compact storage of unit or for work in crawl spaces by backing off the two thumb screws. When replacing the handle, be sure the thumb screw tips engage in the corresponding holes in the handle.